



# BLADE6040

Screeener Assist  
X-ray Baggage Inspection Systems

**BLADE6040** is a X-ray baggage inspection which has a tunnel size of 610 mm by 420 mm and can provide the effective inspection of mail, hand-held baggage, luggage and other items.

It allows identification of weapons, liquids, explosives, drugs, knives, fire guns, bombs, toxic substances, flammable substances, ammunition, and dangerous objects, which are safety hazard by identification of substances with effective atomic number. High image quality in combination with automatic identification of suspicious objects allows the operator to quickly and effectively evaluate any luggage content.

## FEATURES

- Real-time Detection to Aid Operators in Identifying Suspicious
- High Performance – Typical Penetration up to 40 mm of Steel
- Startup with Fingerprint
- Four Layers of Lead Curtain
- Uninterruptible Power Supply
- Equipped with Input & Output Rollers
- Adjustable Conveyor Speed
- Real Time Remote Monitoring System
- Luggage Image and Walk Through Metal Detector Status Display on the Same Screen
- Threat Image Projection (TIP)

## OPTIONS

- Operator Desk
- Video Surveillance
- Gray Paint
- Guard Plate of Rollers (Two layers of lead curtain)
- Eyes on Function (Eye tracking technology to follow the users eye as they operating x-ray inspection. There will be a prompt when the operator's eyes leave the screen.)

# SPECIFICATIONS

(GL Exclusive Feature)

## Technical Characteristics:

Tunnel Dimensions(W*H)	610mm*420 mm
Conveyor Speed	0.20 m/sec ~ 0.40m/sec
Load on Conveyer	Max 200 kg (Evenly Distributed)
Space Defintion	Horizontal 1.0mm Vertical 1.0mm
Steel Penetration	38mm Guaranteed; 40mm Typical
Wire Resolution	38AWG Guaranteed; 40AWG Typical
Dual-energy detector	Yes
Number of Colors in X-ray Image	3
Dimensions(L*W*H)	1987.5*1023.9*1317mm (78.2 in*40.3 in*51.8 in)
Package Dimensions(L*W*H)	2100mm*1200mm*1600 mm (82.6 in*47.2 in*62.9 in)
Package Weight	750kg (1653 lbs)
Film Safety	ASA/ISO1600 standard of film safety
Single Inspection Dosage Rate	s1.0 Gy Radiation Leak Dosage 0.1 Gy/h (5cm from the surface)

## Operating Environment:

Operating Temperature	-10°C to +45°C
Storage Temperature	-20°C to +60°C
Humidity	5-95%, non condensing
Power Supply	230 VAC +/- 10% / 60/50 Hz (EU), 110 VAC +/- 10% / 60/50 Hz (US)
Power Consumption	700W
Sound Pressure	<51.8dB (A)

## X-ray Generator:

Tube Current	0.5-1.0 mA(adjustable)
Anode Voltage	150-170 kV(adjustable)
Generator Cool	Seal oil cooling / 100%

## Computer Specification:

Processor: I7-7700  
 Monitor: 21" LED color  
 Memory: 8 GB DDR4  
 Hard Drive: 240GB SSD+1TB HDD  
 Graphic Card: NVIDIA GeForce GTX 1660 Ti  
 USB Port: 4 ports

## Software features:

Perfect View (PV), Black / White (B/W), Pseudo Colors (PS)  
 Inverse View (IN), High Penetration (HP), Real Time Image Processing  
 Image Zoom(64x), Image of Previous Baggage, Programmable Function Keys  
 Baggage Counter, Date / Time Indicator, Threat Image Projection (TIP)  
 Automated threat identification software, Platform software : ZKBio SIS  
 Monitor the status of walk through metal detector

## DIMENSIONS

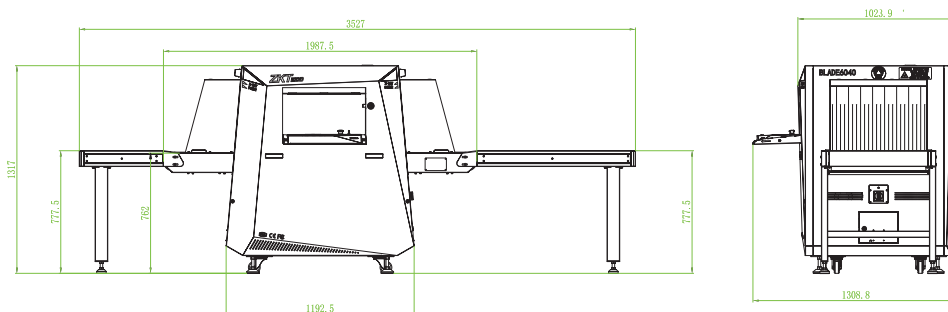

**ZKTeco**  
 USA

1600 Union Hill Road Alpharetta, GA 30005  
 Phone: (862) 505-2101 | Fax: (862) 204-5906 | info@zktecousa.com | www.zktecousa.com

© Copyright 2023. ZKTeco Inc. ZKTeco Logo and ZKTeco USA Logo have registered trademarks of ZKTeco or a related company.  
 All other product and company names mentioned are used for identification purposes only and may be trademarks of their respective owners.  
 All specifications are subject to change without notice. All rights reserved.